

QuickGrip® Adaptors 175-409-1 and 175-435-1

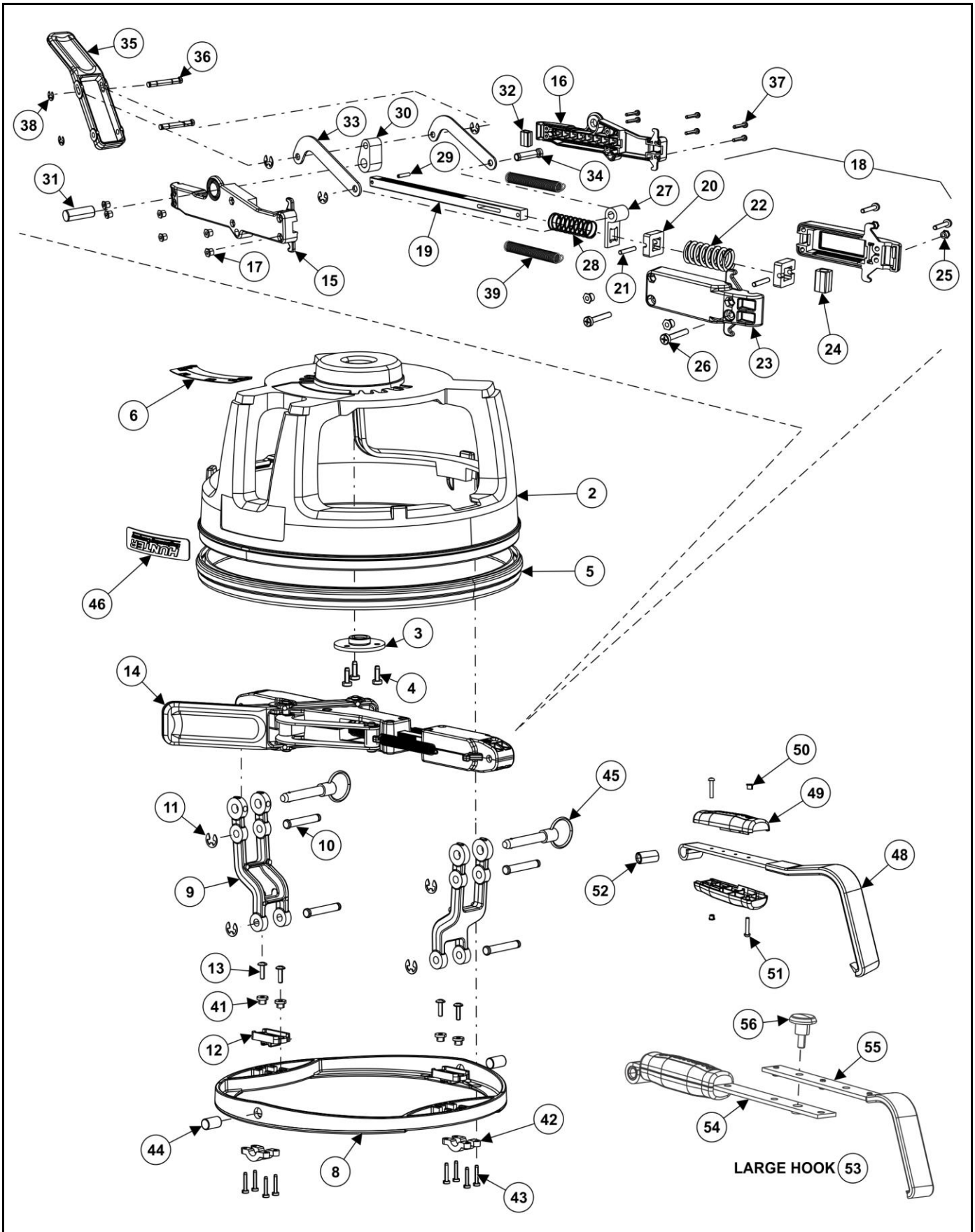

QuickGrip® Adaptors 175-409-1 and 175-435-1

REFER TO NEXT SHEET FOR PARTS DESCRIPTION LISTING

PARTS DESCRIPTION LISTING

Index No.	Part Number	Description	Qty.
1	175-409-1	ADAPTER, 3D TARGET BASE (Consisting Of:)	4
OR	175-435-1	ADAPTER, QUICK GRIP DRIVE UNDER (Not Illus.) (Consisting Of:)	4
2	72-454-2	BASE, CLAMP-ON TARGET	1
3	113-288-2	BUSHING, BASE TARGET	1
4	75-736-2	SCREW, SELF-TAPPING 8-16 X .50 INCH PLASTITE	3
5	179-72-2	SHIELD , PROTECTIVE RING BASE	1
6	128-1265-2	DECAL, TARGET POSITION BASE (For non-DU Adaptor Only)	1
OR	128-1421-2	DECAL, TARGET LOCATOR LEFT (0, 2) (For DU Adaptor Only) (Not Illus.)	1
OR	128-1422-2	DECAL, TARGET LOCATOR RIGHT (1, 3) (For DU Adaptor Only) (Not Illus.)	1
7	12-213-1	CLAMP ASSEMBLY, TIRE GRIP COA (Consisting Of:): (Not Illustrated)	1
8	11-1351-2	SUPPORT, PIVOT RING	1
9	120-101-2	LINK, TIRE CLAMP ADAPTER	2
10	135-463-2	PIN, HI FORCE	4
11	112-100-2	SNAP RING #5133-25	4
12	41-199-2	RTNR, PIVOT PIN	2
13	75-759-3	SCREW, TRUSS HEAD MACHINE SCREW #6-32 X .50 INCH (use Loctite 7649)	4
14	12-214-1	CLAMP ASSEMBLY, BAR HI-FORCE COA (Consisting Of:)	1
15	105-588-2	HOUSING, CLAMP-TOP-3	1
16	105-587-2	HOUSING, CLAMP-BOTTOM-3	1
17	46-512-2	SPACER, THREADED 6-32 X 3/16 INCH	6
18	98-463-1	SPRING ASSEMBLY, HI-FORCE COA (Not Shown) (Consisting Of:)	1
19	57-841-2	BAR, CLAMP	1
20	217-70-2	COLLAR-BAR CLAMP SPRING	2
21	135-465-2	PIN , DOWEL 1/8 X .75 INCH LONG	2
22	98-457-2	SPRING, COMPRESSION COA	1
23	105-589-2	HOUSING, SPRING-BOTTOM-2	2
24	130-208-2	BUSHING, CLAMP TIRE GRIP ADPTR	1
25	46-512-2	SPACER, THREADED 6-32 X 3/16 INCH	4
26	75-738-2	SCREW, PAN HEAD MACHINE SCREW #6-32 X .88 INCH	4
27	172-48-2	CAM, LATCH HI-FORCE CLAMP	1
28	98-428-2	SPRING, LATCH HI-FORCE CLAMP	1
29	135-422-2	PIN, SPRING 1/8 OD X .625 INCH	1
30	172-49-2	CAM, HI-FORCE	1
31	135-333-2	PIN, DOWEL 3/8 X 1.00 INCH LONG.	1
32	130-208-2	BUSHING, CLAMP TIRE GRIP ADAPTOR	1
33	120-100-2	LINK, CLAMP	2
34	135-462-2	PIN, HI FORCE LATCH	1
35	164-94-2	LEVER, TIRE CLAMP ADAPTOR	1
36	135-472-2	PIN, LATCH HANDLE	2
37	75-738-2	SCREW, PAN HEAD MACHINE SCREW #6-32 X .88 INCH	6
38	112-100-2	SNAP RING #5133-25	5
39	98-494-2	SPRING, EXT 1.40 LB/IN. 2.5 FL	2
40	FIELD SUPPLIED	LUBRICANT, 3 IN 1 OIL	A/R
41	46-663-2	SPACER, FLANGED #6	4
42	12-212-2	CLAMP, PIVOT PIN STRAP	4
43	75-734-2	SCREW SELF-TAPPING #4 X .63 INCH HI-LO TX	8
44	135-464-2	PIN, DOWEL 3/8 INCH DIAMETER X .625 INCH LONG	2
45	135-473-2	PIN, DETENT 5/16 INCH DIAMETER X 1.4 INCH GRIP	2
46	128-1299-2	DECAL, HUNTER LOGO	1
47	20-2518-1	KIT-FIXED HOOKS CLAMP ON ADAPTOR	1
48	216-164-1	HOOK ASSEMBLY, FIXED SMALL COA (Includes:)	8
AND	216-163-1	HOOK ASSEMBLY, FIXED MEDIUM COA (Includes:)	8
49	142-169-2	HANDLE, FIXED HOOK	2
50	46-512-2	SPACER, THREADED 6-32 X 3/16	2
51	75-166-3	ROUND HEAD MACHINE SCREW 6-32 X .75 INCH COATED	2
52	106-174-2	SLEEVE, FIXED HOOK	1
53	216-167-1	HOOK ASSEMBLY, LARGE TWO POSITION (Includes:)	8
54	142-235-1	HANDLE ASSEMBLY, LARGE HOOK (Includes:)	1
48-51	SEE ABOVE	INCLUDES HANDLE (See items 48 through 51)	-
55	216-168-1	HOOK ASSEMBLY, LARGE ADJUSTABLE	1
56	34-168-2	KNOB, 1/4-20 X .50 INCH RUBBER	1
57	128-1338-2	DECAL, ELITE HAWKEYE (Not Illustrated)	1
58	128-1373-2 / 128-1392-2	DECAL, WHEEL POSITION GUIDE (Domestic / Export) (Not Illustrated)	2

HUNTER
Engineering Company

11250 HUNTER DRIVE BRIDGETON, MO 63044

PPP-Paint Code Required
A/R-As Required
REF-Reference