

INSTALLATION INSTRUCTIONS FOR BALANCER WHEEL LIFT, 20-3101-1

i NOTE: Service procedures should be performed only by an authorized factory representative.

! **California Warning: This product may contain chemicals known to the State of California to cause cancer and reproductive harm. www.P65Warnings.ca.gov**

This document provides information for the installation of new wheel lift, 72-563-1, using kit, 20-3101-1.

i NOTE: To lift the wheel lift up, actuate the foot pedal upwards. Actuate the foot pedal downwards to lower the wheel lift. The air supply must be connected. It is not necessary for the balancer to be powered on. More detailed instructions are provided in 6910-T.

! **SMART WEIGHT PRO WITH NO HOOD ONLY: A wheel lift with a hoodless Smart Weight Pro is not recommended for safety reasons.**

! **SMART WEIGHT PRO WITH NO HOOD ONLY: If installed, lift must be lowered before starting balancer.**

Air valve preparation

For balancers not already equipped with an air filter/regulator, install filter/regulator, 136-78-2, to back of balancer using two screws, 75-522-2. Hose assembly, 137-96-1, will be attached to regulator.

Disconnect air hose from wall coupling.

Remove plug from regulator on back of balancer.

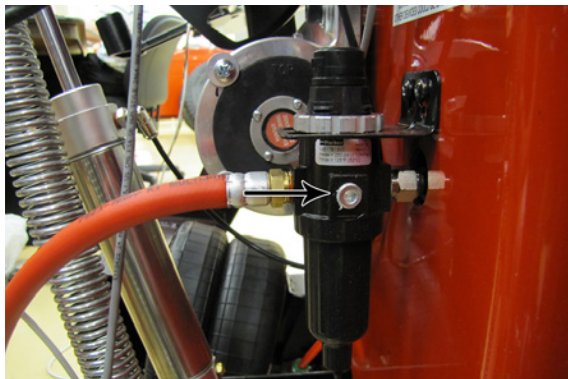

Figure 1: Plug

Install air fitting, 145-367-2, in place of the plug.

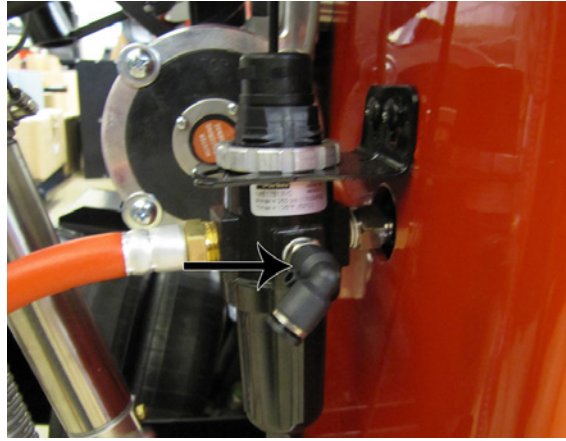

Figure 2: Air fitting.

Two-Way Valve Assembly: 108-162-1, Installation (Touchscreen Balancers & Newer)



SMART WEIGHT PRO WITH NO HOOD ONLY: Do not install the 2-way valve assembly.

Remove weight tray. Mount valve, 108-162-1, to inside wall of balancer tub using two flat washers, 77-79-2, two #4-40 pan head machine screws, 75-544-2, and two lock nuts, 76-366-2. Install with the screw heads and washers on the outside of the tub as shown.

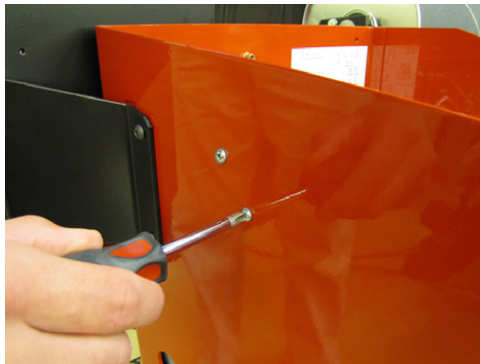

Figure 3:

The valve should be positioned so that the OUT side of the valve faces the rear of the balancer tub.



Figure 4: Two Way Valve



CAUTION: Take care routing the exhaust airline. Exhaust air may contain moisture.

Insert supplied 5/16" airline into OUT side of valve. Route the airline out of the tub, making certain to point the end of the line away from electrical connections.



Figure 5:



Figure 6:

Connect valve wires to the WHEEL LIFT connector on the DAQ board. Refer to the diagram stick in the tub if necessary. (RFT DAQ board shown).

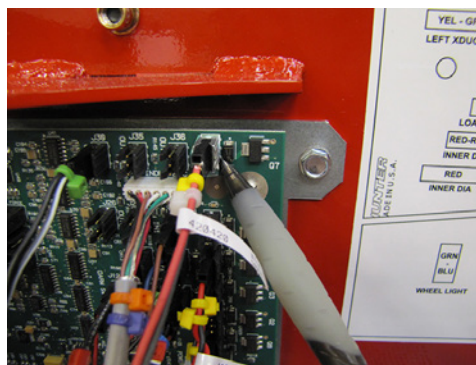

Figure 7: Road Force Touch DAQ Board



Figure 8: SWP DAQ Board

Two Way Valve Assembly, 108-162-1, Installation (other Balancers)

Remove weight tray. Mount valve, 108-162-1, to inside wall of balancer tub using two flat washers, 77-79-2, two #4-40 pan head machine screws, 75-544-2, and two lock nuts, 76-366-2. Install with the screw heads and washers on the outside of the tub as shown.



The valve should be positioned so that the OUT side of the valve is pointing downwards.

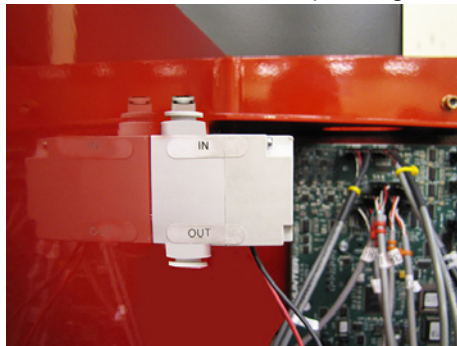

Route the supplied 5/16" airline from the OUT side of the valve down through the balancer tub and out of the appropriate hole.

Connect valve wires to the WHEEL LIFT connector on the DAQ board.

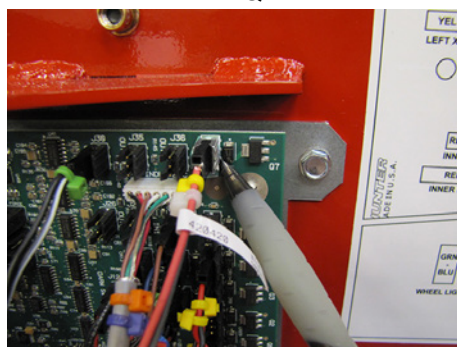

Figure 9: RFT DAQ

Lift Installation Instructions:



CAUTION: Take care when positioning the wheel lift unit, 72-563-1. Do not damage the airlines.

With the balancer sitting in the desired location, set the wheel lift unit, 72-563-1, in place. Do not mount the lift to the balancer yet.

Some steps during wheel lift installation will be easier with lift in the raised position. Prevent scissor legs from collapsing by inserting a screw drive through the hole in inner leg, near pivot.

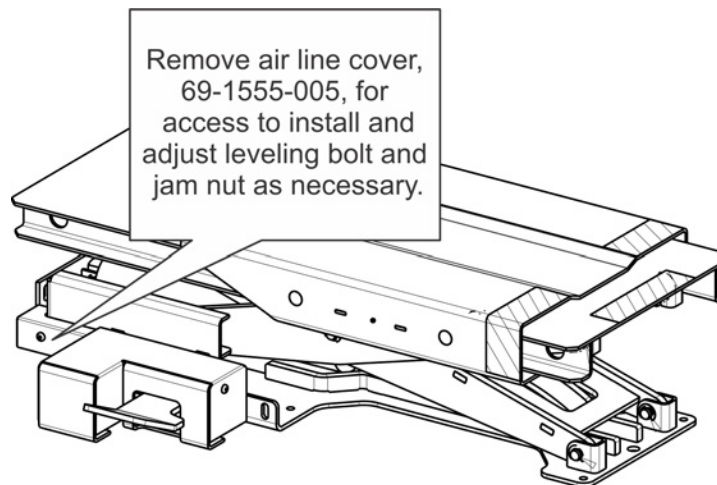

Figure 10:

Check that the wheel lift unit, 72-563-1, is sitting flat on the floor and making contact at all six pad locations beneath the base.



NOTE: Air line cover, 69-1555-005, must be removed to access forward left leveling bolt threads in wheel lift base.



For uneven floors, 1/4-20 x 1.25 inch socket head cap screws, 75-797-2, may be installed into any or all of the six base pads to level the lift. Install a jam nut, 76-51-2, with each screw and tighten the nut to the base plate when the proper height is set.



Figure 11:

Locate airline access hole next to the wheel lift mount inserts. Access hole comes plugged from the factory. Remove and discard the plug.



Figure 12:

Remove and discard zip tie securing airline bundle. Identify airlines: 5/32" airline that is attached to the "Y" fitting on the back side of the wheel lift and the other airline. Note the differing lengths.



Figure 13: Y fitting shown



SMART WEIGHT PRO WITH NO HOOD ONLY: Remove the "Y" fitting and discard. Run 5/32 air line from foot valve and directly install to lift cylinder.

Slip supplied grommet over both airlines. Send the longer airline through the tub first. Once the longer airline is through, tape the shorter airline to it and pull the airlines the rest of the way into the tub. Insert the grommet into the access hole.

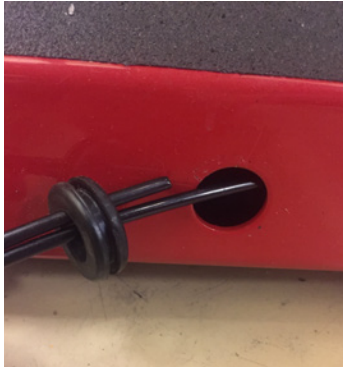

Figure 14: grommet on air line.

Both air lines should be routed inside the tub wherever possible to protect them from damage. There is an opening between the side foot panel and the RH tub wall. Route both air lines through this opening and back out through the square cutout in the rear tub wall. The tub may need to be elevated to provide easier access.

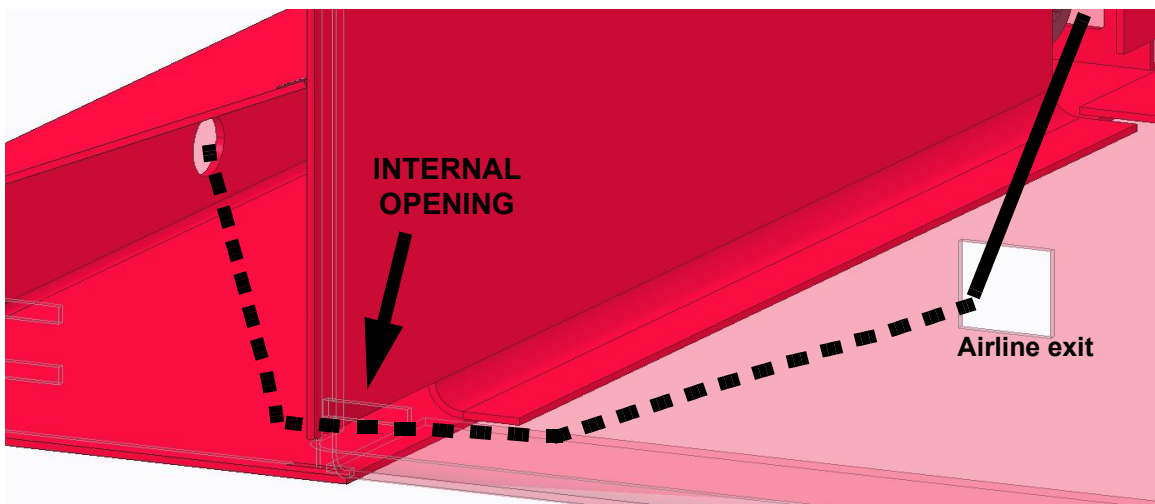

Figure 15: air line routing through the tub

Alternatively, the longer air line can be routed directly up through the tub floor instead of out the back. Tie down with supplied zip ties if routing externally.



Figure 16: Air lines routed out back and zip tied

Attach the longer 5/32" airline to the IN side of valve located inside the tub, 108-162-1. (Valve in touchscreen balancer shown.)



Figure 17: 108-162-1 Valve

Attach the shorter airline to the elbow fitting, 145-367-2, previously installed on the air regulator. Route both airlines to avoid damage from moving components. Use supplied cable ties to keep them secured properly as necessary.

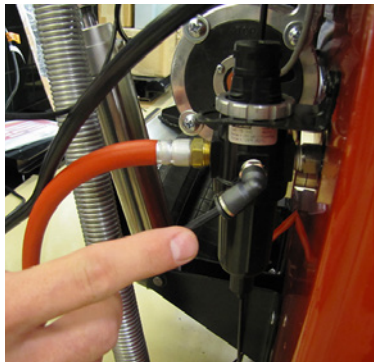

Figure 18: shorter airline to elbow

Re-connect the balancer air hose to the wall coupling.

Raise the lift so that there is enough room to work while attaching the wheel lift to the balancer. Take the weight guard, 51-3112-000, and rest the guards' lip against the lift's mounting bracket area so the attachment holes line up. Then thread a 5/16-18 X 1 inch socket head cap screw (SHCS), 74-12-2, and a flat washer, 77-20-2, through each hole.

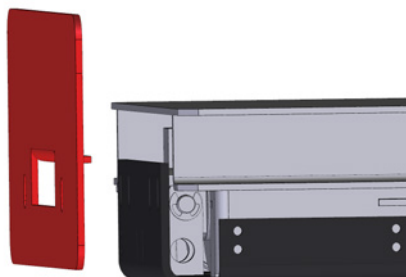

Figure 19: weight guard



Figure 20: weight guard

On the weight guard side place a rubber washer, 77-434-2, on each of the socket head cap screw's that are poking through. The rubber washers must be placed between the balancer and the plate weight guard to serve as a vibration dampener. Slide the lift towards the balancer with the plate guard in place and attach to the balancer.

If using the weight guard in conjunction with retainer foot plates, Kit 20-3575-1, follow the alternative install method for the weight guard as provided in the next chapter.



Figure 21:

With the balancer powered ON, raise the lift to any position. Lower the hood and confirm that the lift automatically lowers to the floor. If it doesn't, check that the two-way valve's wires are connected to the DAQ board correctly.

Check the operation of the wheel lift trolley by moving it back and forth. The trolley can be adjusted to move slower or faster by tightening or loosening the adjustment screw on the back side of the trolley. Be sure to re-tighten the jam nut when finished with adjustment.

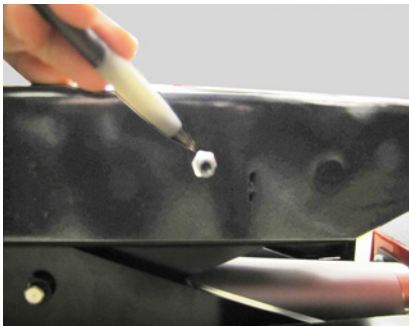

Figure 22:

The trolley stop position is set for full travel from the factory. For sites with space constraints, the stop position may be moved closer to the balancer. To do this, remove the BHCS and nut from the rear roller guide. Install them into the other screw hole, making sure the screw head is on top and the nut is on bottom.

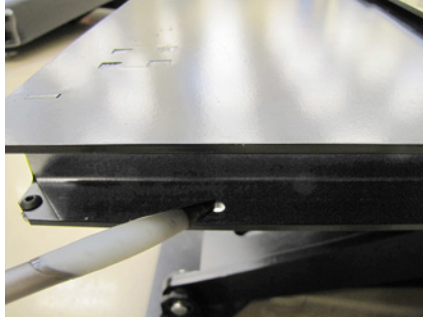

Figure 23:

With the wheel lift installed correctly and all adjustments made, re-attach weight tray and return balancer to service.

FOOT RETAINER PLATE KIT 20-3575-1 INSTALLATION

These install instructions provide an alternative method for installing a balancer wheel lift and weight dam in conjunction with foot retainer plates as part of Kit 20-3575-1. This method allows the balancer to be tipped up and cleaned beneath while keeping the wheel lift stationary.

BALANCER FOOT RETAINER PLATE INSTALL

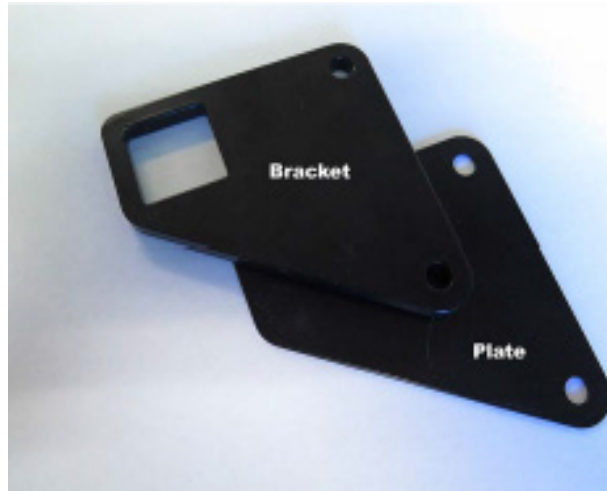

Tools Needed:

- Drill (hammer drill recommended)
- 1/4 inch masonry drill bit
- Hammer
- 7/16 socket

Place the bracket on top of the plate with the holes lined up. The plate prevents floor wear.



The balancer should be in its operational location. With caution, slightly tilt the balancer and place a retainer plate and bracket set under each balancer foot.



Figure 1: Place retainer plates under feet

Make sure the plate and bracket holes are aligned. Use a 1/4 inch bit and drill the thunderstud holes.



Figure 2: Drill holes - 1/4 inch bit

Make sure the nut and washer are screwed on to the end of the thunderstud. Hammer the studs into the place



Figure 3: Hammer in stud

With the stud in place use a socket to hand tighten the nut to approximately 4 ft-lbs. Do not over tighten.



Figure 4: Tighten nut to firm - Don't over tighten

PLATE WEIGHT GUARD INSTALLATION

Tools Needed:

- Allen wrenches

Take the plate weight guard, 51-3112-000, and line the holes up to the balancer attachment holes. The guards' lip should be facing away from the balancer.

Then thread a 5/16-18 X 1 inch socket head cap screw (SHCS), 74-12-2, through each hole.

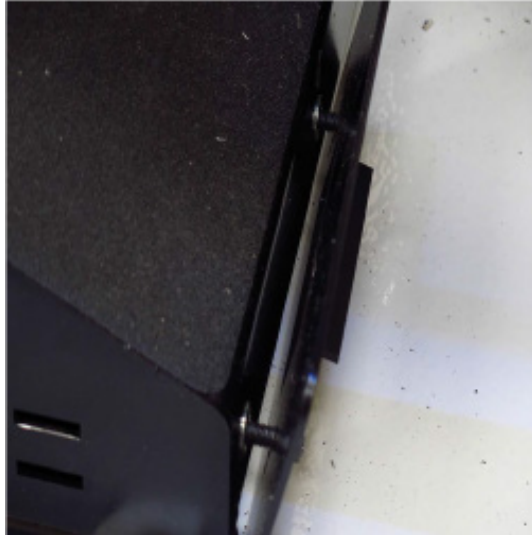

Figure 5: Thread screw and washer through guard

Use a 1/4 inch Allen wrench to tight the screws.



Figure 6: Secure guard to balancer

Align the wheel lift attachment holes with the socket head cap screws that are securing the weight guard. Move the lift in close to the balancer.

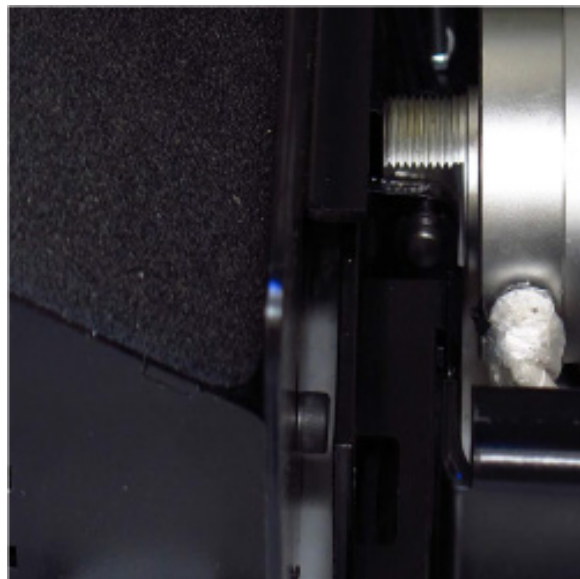

Figure 7: Wheel Lift Aligned with bracket

WHEEL LIFT FLOOR INSTALLATION.

Tools Needed:

- Drill (hammer drill recommended)
- 3/8 inch metal drill bit
- 1/4 inch masonry drill bit
- Hammer
- 7/16 socket

Newer wheel lift will come with pre-drilled holes for anchoring the lift.

14

If your retro-fitting the lift you will need to drill the anchor holes. Use a 3/8 metal bit to drill a hole through the metal base. The hole should be 1/2 inch from the side of the bracket and 1/2 from the end of the bracket.

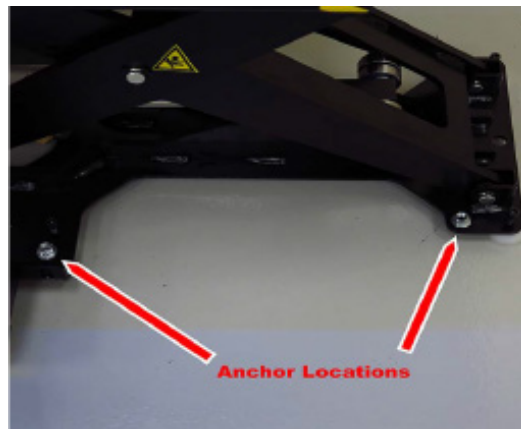

Figure 8: Locate drill points.

Use the metal drill bit to only drill through the metal bracket.



Figure 9: Use a 3/8 metal bit to drill bracket holes

With the bracket holes drilled (or already there) switch to a 1/4 inch masonry bit and drill at least 1 1/2 inch hole in the concrete.



Figure 10: Use 1/4 inch masonry bit to drill the concrete

On the thunderstud place the washer 1/4 down on the threads.



Then pound the thunderstud into place and tighten with a 7/16 socket to tighten up the thunderstud to hand firm. Do not over tighten.

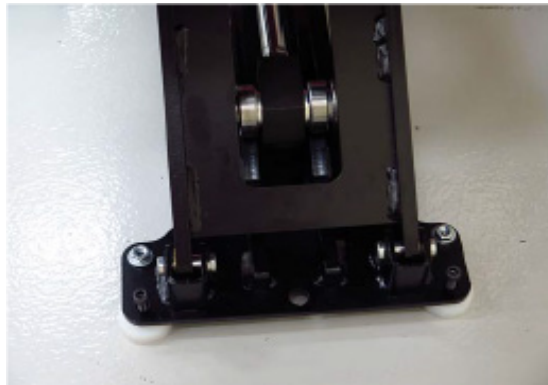

Figure 11: Tight with 7/16 socket